

---

## PART 1 GENERAL

### 1.1 General

- .1 Conform to the requirements of Division 1

### 1.2 Related Sections

- .1 Section 03 10 00 Concrete Forming and Accessories
- .2 Section 03 20 00 Concrete Reinforcing
- .3 Section 03 30 00 Cast-in-Place Concrete
- .4 Section 07 21 13 Building Insulation
- .5 Section 07 26 00 Vapour Retarders
- .6 Section 31 23 10 Excavating, Trenching and Backfilling

### 1.3 References

- .1 Canadian Standards Association (CSA)
  - .1 CSA B52-13 Mechanical Refrigeration Code
- .2 Technical Standards & Safety Authority (TSSA)
  - .1 TSSA Operating Engineer's Act
  - .2 TSSA Piping Systems Design Registration
- .3 Technical Standards and Safety Act, 2000, S.O. 2000, c. 16
- .4 The American Society of Mechanical Engineers (ASME)
  - .1 ASME Boiler and Pressure Vessel Code, 2015
- .5 American National Standards Institute (ANSI)
  - .1 ANSI B31.5-2001 Refrigeration Piping
- .6 Ontario Occupational Health & Safety Act for Industrial Establishments

### 1.4 Submittals

- .1 Make submittals in accordance with Section 01 33 00 – Submittal Procedures.
- .2 Submit shop drawings for complete ice rink refrigeration floor and piping including layout showing all access and service boxes.
- .3 Submit technical data sheets for pipe insulation and jacketing, polyethylene rink piping, rink pipe supports and access boxes.

### 1.5 Related Work Supplied and Installed by Other Divisions

- .1 The ice rink refrigeration contractor shall co-ordinate all phases of his work with the general contractor and all other subcontractors including related work as listed. Overall project coordination is the responsibility of the general contractor.
- .2 General:
  - 1. Cutting, patching, sleeving, sealing and fireproofing of floor, wall and ceiling openings for all refrigeration system piping and electrical conduits.
  - 2. Cutting of existing perimeter concrete and any sub grade trenching for access box placement and routing of buried brine piping.
  - 3. Trench cover removal and disposal by General Contractor.
  - 4. Placement of inserts.
  - 5. Cleaning of existing header trench.

6. Dasher board and glass removal and dispose of prior to header removal.
7. Provide compaction test results (98% standard proctor density)
8. Copy of an independent floor survey to prove the floor is +/- 3-16"
9. All excavation, trenching, backfilling and compaction required for buried piping.
10. All rink concrete slab subfloor excavation, multiple lifts and placement of sand, sand compaction and leveling as required.
11. Excavation and back filling for placement of two (2) access vent boxes, concrete slab box-outs and pouring of box-outs. Box-outs shall be poured after valve boxes installed mains and rink headers tied into buried.
12. All rink subfloor insulation and polyethylene slip sheet as required.
13. All re-enforcing steel and welded wire mesh for rink floor construction.
14. All concrete supply, placement and finishing for rink floor construction.
15. Expansion joint material and installation as required.
16. Apply and maintain a 7 day wet cure.
17. Temporary lighting, heating, 120V power and water shall be provided during construction stage.
18. Permanent water supply shall be available at 345 kPa (50 psig).
19. Disposal of waste material as a result of our scope of work
20. Dumpster bin rental and coordination
21. Provide a storage area of refrigeration material and equipment for entirety of project
22. Safety fencing to protect material against damage for the entirety of project
23. Any/all cleaning of new arena slab(s)
24. Any/all cleaning of arena bowl, bleachers, windows, walls etc.
25. Any/all seismic responsibilities
26. Any/all Publications for notice of completion etc. in order to receive payment (if applicable).
27. Provide refrigeration contractor with a level surface +/- 3/16"
28. Ice making or first sheet of ice on new refrigerated concrete slab will be completed by the Municipality.
29. Installation of any inserts. (normally completed by dasher board company)
30. Provide sufficient rebar tie back device/support to allow refrigeration contractor to install tie back supports for rink piping.

#### 1.6 Quality Assurance

- .1 The refrigeration contractor shall use only skilled welders, each holding a current, active welding certificate with TSSA.
- .2 Workmanship throughout shall conform to standard of best practice; labour employed shall be competent to do the work.
- .3 The refrigeration contractor shall be able to provide warranty service work to the equipment after installation for the warranty period specified.
- .4 Verify all existing site conditions.
- .5 Pre-Construction Conference:
  - .1 Arrange a rink slab pre-installation conference with the Owner, Consultant, General Contractor, reinforcing installer, floor finishing contractor, concrete supplier, manufacturer of admixture products, refrigeration contractor, and independent testing agency, to establish correct procedures and methods for placing concrete rink slabs. The meeting will be held within seven days prior to the placing of rink slab sand layer.

#### 1.7 Shipping, Handling and Storage

- .1 Refer to Section 01 16 00 – Common Product Requirements.
- .2 Deliver, handle and store materials in accordance with manufacturer's printed instructions.

#### 1.8 Waste Management and Disposal

- .1 Refer to Section 01 74 10 – Cleaning.

#### 1.9 Warranty

- .1 The refrigeration contractor shall warrant the material and installation specified hereunder against original defects in manufacture and workmanship for a period of two (2) year after acceptance by the Owner.

### PART 2 PRODUCTS

#### 2.1 Brine Piping

- .1 Supply and install all the necessary brine pipe and fittings for connection of cooling and underfloor heating brine distribution headers to the existing pumps and heat exchangers located in the refrigeration compressor room. Brine pipe shall be schedule 40 ASTM A53 grade A or B ERW steel pipe. Pipe fittings to be carbon steel butt weld with identical wall thickness as the steel pipe.
- .2 The open ends of carbon steel pipe lengths to be shipped to the construction job-site shall be sealed with plastic protective caps.
- .3 Brine piping installed in an excavated trench shall be supported on pressure treated lumber during the installation and prior to back-filling.

#### 2.2 Cooling Brine Headers for Rink Floor

- .1 Supply and install factory fabricated 6" schedule 40 ASTM A53B steel pipe headers with ¾" schedule 80 seamless steel 135 degree bent nipples welded and spaced at 8" centres. Ends of nipples shall not protrude into the 6" pipe.
- .2 The return and supply cooling brine header sections shall be mounted on and welded to structural steel supports suitable for placement on rigid insulation trench and for installation in thickened portion of concrete rink slab.
- .3 Connections for access / vent valve piping shall be welded on the job-site to suit.

#### 2.3 Cooling Rink Floor Polyethylene Piping

- .1 All rink floor piping shall be 1.049" ID x 1.25" OD linear low density, virgin polyethylene resin, CSA approved pipe that has been specifically manufactured for rink use.

- .2 Rink floor cooling brine piping shall be installed on 100 mm centres. The only permitted connections or joints in the cooling floor piping, shall be at the headers and at the 180° return bends. Pipes shall be fastened to the header and return bends via stainless steel clamps & screws, two (2) clamps per pipe connection.
- .3 Return bends shall be PVC, adequately supported to prevent twisting.
- .4 The rink cooling floor and header system shall be tested with water pressure at a minimum of 345 kPa (50 psig) for 48 hours, prior to pouring of concrete. Pressure shall remain on the floor and header piping for the duration of the rink concrete and pour.
- .5 Supply and install a rebar tie-back device at both ends of the rink floor for tensioning the rink piping. Secure the return bends to the rebar with wire ties.
- .6 Return bend wire ties are to be cut after the concrete floor pour, through the perimeter side of the expansion joint to permit the floor slab to contraction during operation.

#### 2.4 Rink Cooling Pipe Supports

- .1 Supply and install rink pipe support chairs made of steel rod fabricated with a 76mm wide, 24 gauge steel base plate on the bottom. Rink pipe supports shall be fabricated to lift the polyethylene pipe to allow a maximum of 1-3/4" [44mm] thick concrete coverage over the top of rink piping.
- .2 Pipe chairs shall space the cooling rink floor piping on 100 mm centres and shall be placed in rows on 610 mm centres down the length of the rink. Overlap chairs by one (1) pipe at the end of each chair.
- .3 If the top layer of reinforcing steel is welded wire mesh, M-Type top loading reinforcing support chairs are acceptable at the ice rink slab to support rink slab piping and reinforcing steel provided that the tying of the mesh is completed at increased intervals acceptable to the Owner and Consultant to prevent movement of the chair racks during pours.

#### 2.5 Cooling Header Access / Vent Boxes

- .1 Supply and install an access box with a removable cover in the perimeter concrete at each end of the cooling brine headers. Access boxes shall be suitable for gaining access to purge / vent valves piped to the ends of each of the cooling brine headers.
- .2 Each access box shall be 300 mm high, fabricated from HDPE rigid plastic and have an open bottom.
- .3 Access boxes shall be installed prior to pouring of the perimeter concrete slab and cast in place with the removable cover flush with the finished elevation of the concrete slab.
- .4 Access boxes shall be Carson Model 1419-12 or equal.

#### 2.6 Painting

- .1 All shop fabricated piping shall be painted with one coat of industrial finish enamel. Touch up any abrasions as required after equipment is installed and construction is complete.
- .2 All field-fabricated steel structural steel or piping shall be painted with a rust resistant primer.
- .3 All un-insulated steel piping shall be painted with industrial machinery enamel paint with colours to match accepted trade standards.

#### 2.7 Pipe Covering and Insulation

- .1 All heating brine steel pipe which is installed in an excavated trench and will be buried, shall be covered with Henry WP200 Blueskin or equal self-adhering protective water proof membrane.
- .2 All cooling brine steel pipe which is installed in an excavated trench and will be buried, shall be insulated with DOW SM rigid polystyrene insulation and covered with Henry WP200 Blueskin or equal self-adhering protective water proof membrane.
- .3 All cooling brine steel pipe which is installed above grade, shall be insulated with ITW Tyrmer 2000 rigid insulation and covered with Henry WP200 Blueskin and PVC jacketing.
- .4 All insulated piping to be painted with rust resistant primer after pressure testing and prior to insulation or jacketing.

#### 2.8 Temperature Sensors and Electrical Conduit

- .1 Provide new electrical conduit body and low voltage conductors for installation of new temperature sensors located in the underfloor heating sand bed elevation and in the concrete rink slab. Connect low voltage wiring to the existing refrigeration system temperature control system.
- .2 Install a new electrical conduit run in the buried piping excavated trench and terminate the wiring at the existing temperature controller and the rink floor temperature sensors.

#### 2.9 Identification

- .1 All above grade brine piping installed under this specification shall be identified after painting and insulation with the fluid in the pipe and the direction of the flow. All lines penetrating walls or roofs must be immediately identified on either side.

### PART 3 EXECUTION

#### 3.1 Preparation

- .1 Carefully inspect the condition and arrangement of existing piping and make all allowances for connecting the new rink slab piping and headers to the existing refrigeration system equipment.
- .2 The general contractor to saw cut existing concrete slabs to expose existing buried piping. Disconnect and remove all existing refrigeration brine piping.

#### 3.2 Rink Floor

- .1 Rink slab as specified in Section 03 30 00.

---

### 3.3 Brine Charge

- .1 The existing calcium chloride brine solution charge is to be fully replaced.
- .2 Prior to beginning demolition of the existing concrete rink floor and brine mains, drain and dispose the calcium chloride brine charge from the cooling piping.
- .3 Pressure test the new brine piping with water to a minimum of 345 kPa (50 psig) for 48 hours. Prior to charging of brine, drain the pressure test water to building drains.
- .4 Prior to charging the brine solution into the new piping, flush the new piping system with water.
- .5 Brine charge is to be introduced to the floor only with DI water. Allow for complete new brine replacement charge.

### 3.4 Start Up and Ice Making

- .1 After the concrete is cured and the rink slab pull down procedure is completed, the owner's personnel shall install the first sheet of ice on the new rink floor.

### 3.5 Refrigeration System Commissioning

- .1 The ice refrigeration contractor shall be solely responsible for charging of brine (as per article 3.3). The refrigeration system shall be commissioned by the Owner's representative or qualified refrigeration mechanic including testing and adjusting all operating controls.
- .2 The procedure for the initial rink concrete slab controlled temperature reduction and making of the first sheet of ice is as follows:
  - .1 A minimum 28-day cure period is required on the concrete prior to reducing the floor temperature.
  - .2 The new concrete slab should be thoroughly cleaned and rinsed. A non-oil based detergent type soap, can be applied by a power scrubber or hand mopped. Ensure any traces of petroleum-based distillates have been removed. (not by refrigeration contractor)
  - .3 Reduce the concrete slab temperature down to 0°C. The full compressor capacity of the system will be used to minimize the time required to reduce the floor concrete slab temperature to 0°C.
  - .4 Maintain the concrete slab temperature at 0°C for 24 hours.
  - .5 Reduce the concrete slab at a rate of 2°C per day until a temperature of approximately -7°C is reached.
  - .6 Owner's representative begins ice-making process.

### 3.6 Cleaning

- .1 Proceed in accordance with Section 01 74 10 – Cleaning.

End of Section



BARRY BRYAN  
ASSOCIATES

Architects  
Engineers  
Project Managers

## Addendum No. 1

Page 1 of 1

**Project No.:** 20248  
**Date:** January 15, 2021  
**Project:** Petawawa Civic Centre Rink Slab Replacement, 16 Civic Centre Road,  
Petawawa, Ontario

The following information supplements and/or supersedes the original bid documents.

This Addendum forms part of the contract documents and is to be read, interpreted, and coordinated with all other parts. The cost of all contained herein is to be included in the contract sum. The following revisions supersede the information contained in the original drawings and specifications issued for the above-named project to the extent referenced and shall become part thereof.

### GENERAL ADDENDUM ITEMS

- 1.1 The mandatory pre-bid site visit has been cancelled due to the current COVID restrictions. However, the project tender will move forward as scheduled without the pre-bid walk through. The Town will provide facility photographs within the effected area to outline the existing conditions. **General Contractors** who are still interested in attending the site shall formally submit a request and a scheduled appointment will be made with the Town stakeholder to provide the requested access. Please note that only access to the facility will be provided for those who wish to attend, this is not mandatory for bidding purposes. There will not be opportunities at the time of a walk through for questions and discussions on the site. All questions must be submitted formally for response by addendum through the Town.
- 1.2 The shop drawings for the existing vertical lift gate are attached to this addendum for reference.
- 1.3 Refer to attached revised specification section 13 18 30.

### QUESTIONS

- 1.4 I see the tender for the Floor Replacement was issued today on Merx. In the dasher board approved manufacturers section I see that Sound Barriers is not named. I submitted the attached in late December for consideration, and I assume that the tender document was already prepared for release prior to receipt of my request. Can you please advise if we will be approved via addendum in the near future.

**Answer:** *Sound Barriers is an approved equivalent.*

### END OF ADDENDUM NO. 1

#### Barry Bryan Associates

*Architects, Engineers, Project Managers*

Doug McLaughlin, P.Eng.

DM/

**Attachments:** Existing Lift Gate Shop Drawings  
Specification Section 13 18 30

1 Page  
6 Pages



250 Water Street,  
Suite 201  
Whitby, Ontario  
Canada  
L1N 0G5

Tele: 905-666-5252  
Toronto: 905-427-4495  
Fax: 905-666-5256  
Email: bba@bba-archeng.com  
www.bba-archeng.com

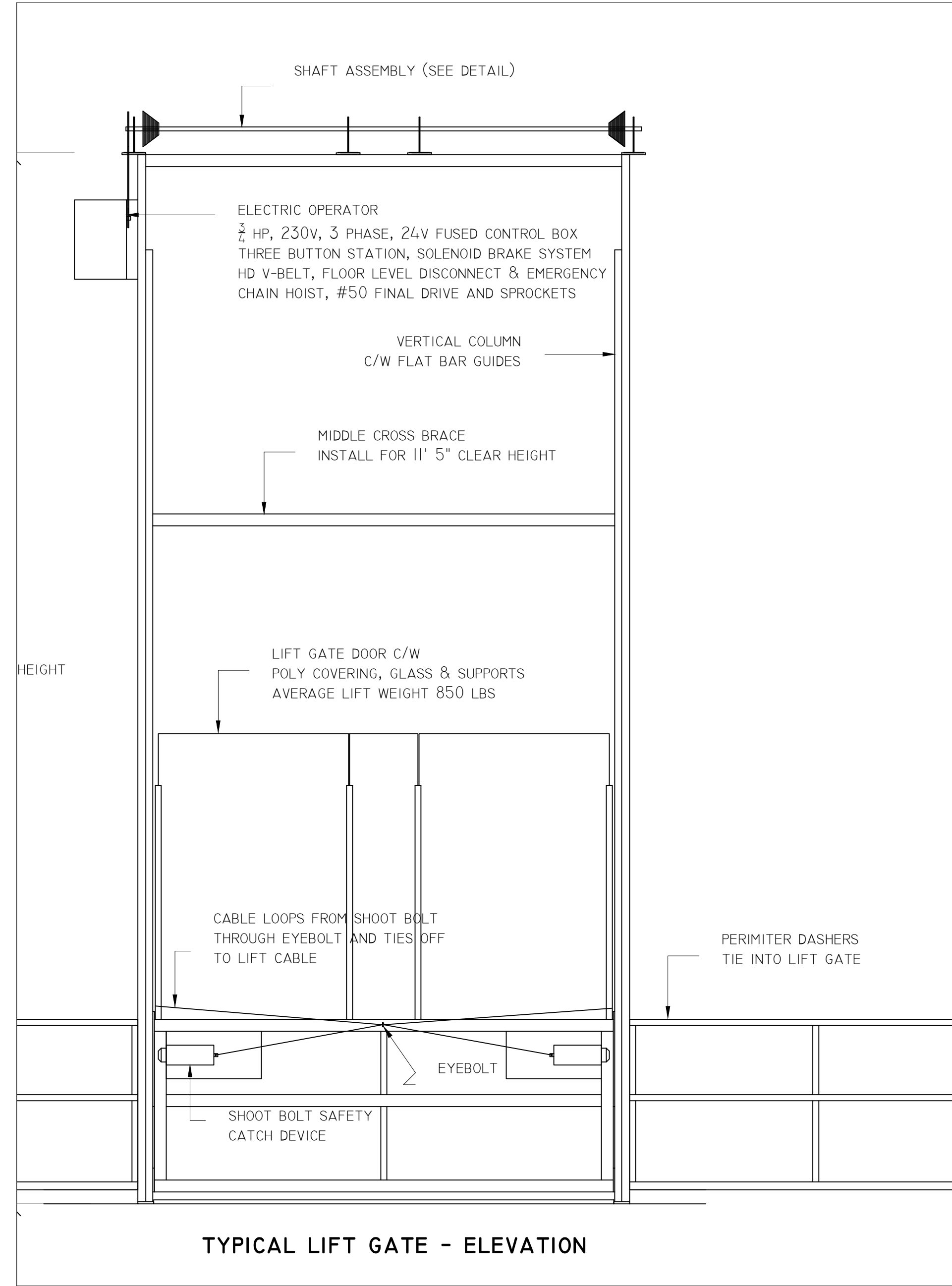

TYPICAL LIFT GATE - ELEVATION

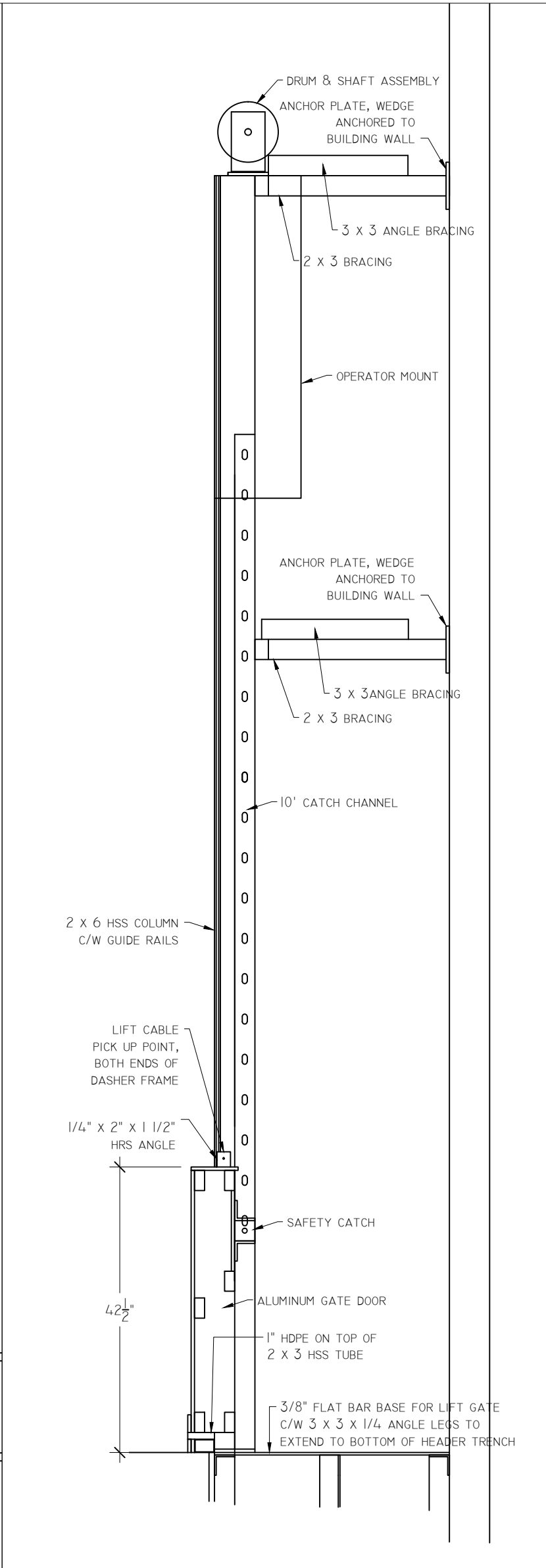

TYPICAL SECTION DETAIL THROUGH LIFT GATE

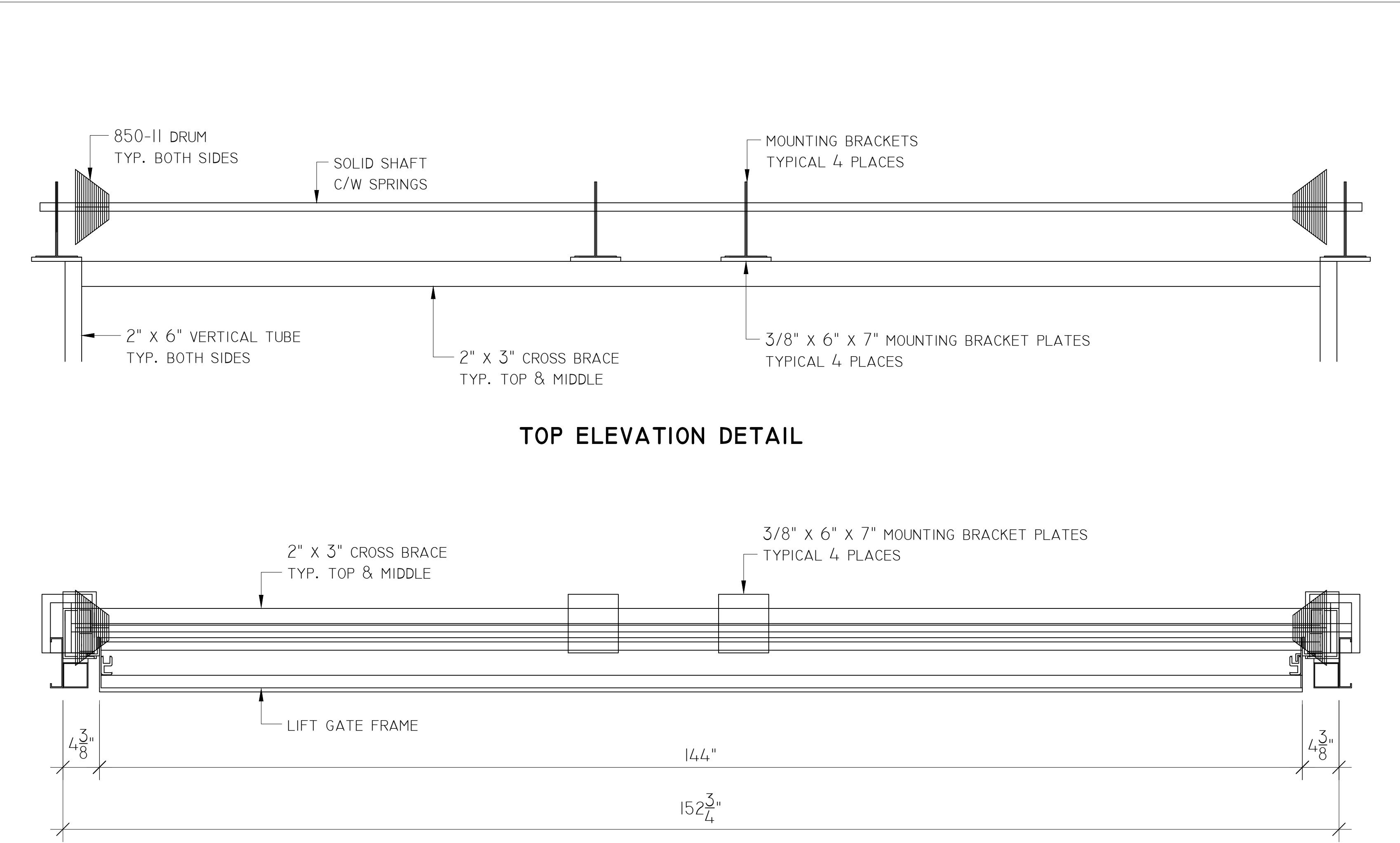

TOP ELEVATION DETAIL

TOP PLAN VIEW DETAIL

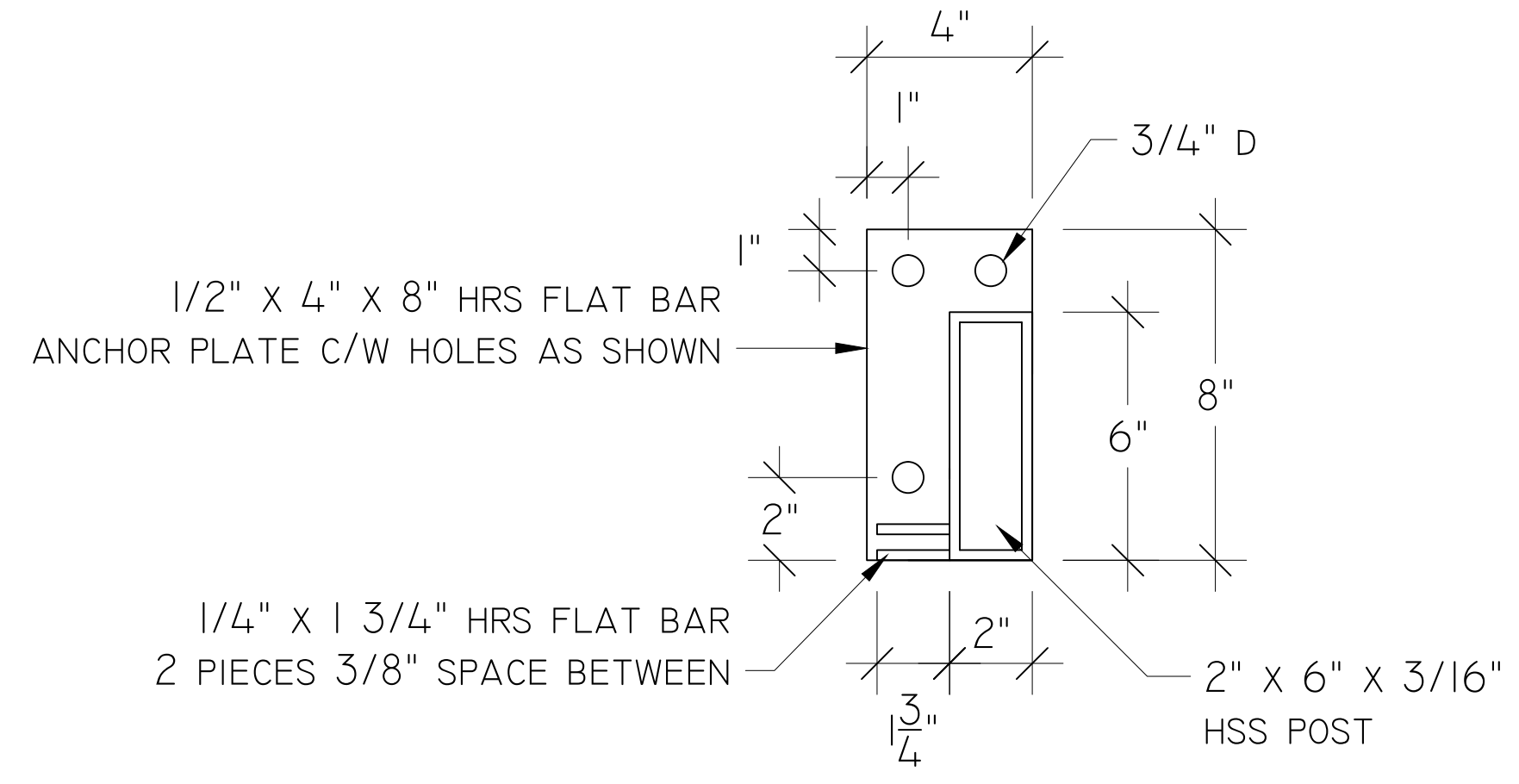

VERTICAL POST ON PLATE DETAIL

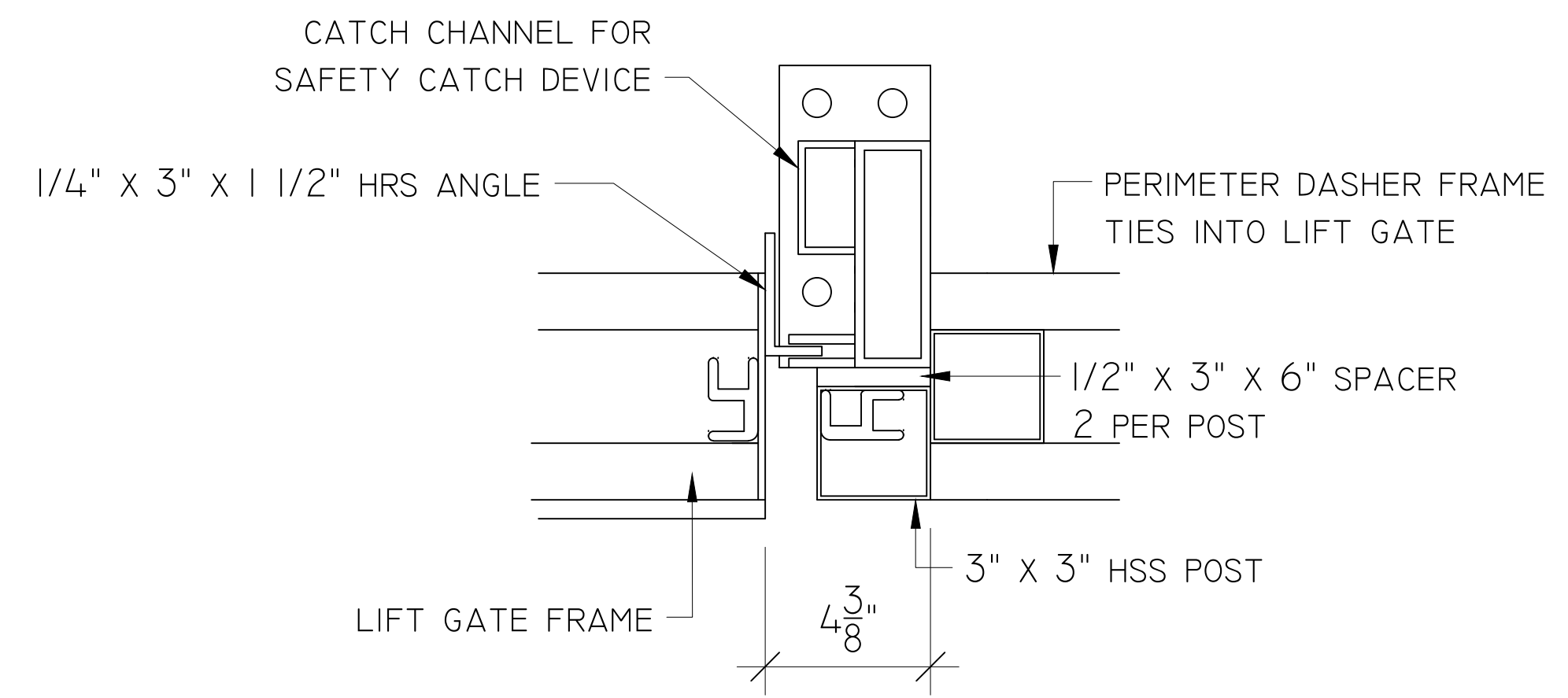

CONNECTION DETAILS

# SOUND BARRIERS

2390 DREW ROAD  
 MISSISSAUGA, ONTARIO  
 L5S 1B8  
 PHONE: 905-678-7465  
 TOLL FREE: 800-252-9498  
 FAX: 905-678-7460

DRAWN BY: BMC	REV NO: 0
CHECKED BY:	DRAWING NO: VLG-01
DATE: 19/06/13	
SCALE: NTS	
PROJECT: TYPICAL LIFT GATE	
LOCATION: VARIOUS, ON	